

Positioning system MLZ 60, 60S, 80, 80S, 100

Belt drive

Specifications

3.1

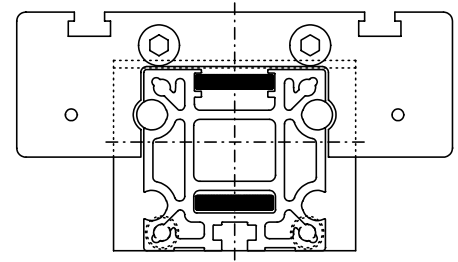
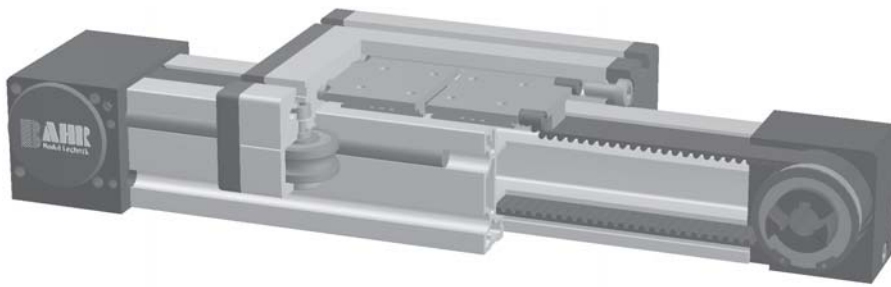

Function:

This linear unit consists of an aluminium square profile with integrated, hardened steel guide rods. The carriage which has internal linear ball bearings, that can be adjusted free of play is driven along the guide rods by a timing belt. The advantage of this system is that the belt is guided within the profile, ensuring that the belt is always tight and thus enabling the system to be operated e.g. when lying on its side. The pulleys have maintenance-free ball bearings. Belt tension can be readjusted by a simple screw adjustment device in the carriage. This device can also be used for symmetrical adjustment of two or more linear units running parallel.

Fitting position:

As required, max. length 6.000 mm without joints.

Carriage mounting:

By T-slots.

Unit mounting:

By T-slots or tapped holes in the bearing block, mounting sets.

Belt type:

HTD with steel reinforcement, no backlash when changing direction,

repeatability: $\pm 0,1$ mm.

Forces and torques	Size	MLZ 60		MLZ 60 S		MLZ 80		MLZ 80 S		MLZ 100	
	Forces/Torques	static	dynamic	statisch	dynamisch	static	dynamic	static	dynamic	static	dynamic
	F_x (N)	894	800	894	800	1900	1800	1900	1800	4000	3800
	F_y (N)	3000	2000	4100	3100	3000	2000	4600	3600	8000	6500
	F_z (N)	1700	1100	2160	1600	1700	1100	3000	1800	3600	2200
	M_x (Nm)	67	43	88	65	90	55	170	140	300	230
	M_y (Nm)	90	70	190	140	110	80	270	230	400	270
	M_z (Nm)	120	100	230	170	150	120	300	220	750	500
All forces and torques relate to the following:											
existing values											
values of table											
$\frac{F_y}{F_{y_{dyn}}} + \frac{F_z}{F_{z_{dyn}}} + \frac{M_x}{M_{x_{dyn}}} + \frac{M_y}{M_{y_{dyn}}} + \frac{M_z}{M_{z_{dyn}}} \leq 1$											
No-load torque											
Nm	0,6		0,7		0,9		1,2		1,4		
Speed											
(m/sec) max	5		7		6		8		10		
Tensile force											
permanent (N)	900		900		1900		1900		4000		
0,2 sec (N)	1000		1000		2090		2090		4300		
Geometrical moments of inertia of aluminium profile											
I_x mm ⁴	4,83x10 ⁵		4,83x10 ⁵		17,49x10 ⁵		17,49x10 ⁵		39,4x10 ⁵		
I_y mm ⁴	5,03x10 ⁵		5,03x10 ⁵		18,02x10 ⁵		18,02x10 ⁵		43,5x10 ⁵		
E-Modulus N/mm ²	70000		70000		70000		70000		70000		

For life-time calculation of rollers use our CD-ROM or homepage!

Formula: MLZ

Driving torque:

$$M_o = \frac{F \cdot P \cdot S}{2000 \cdot \pi} + M_{leer}$$

$$P_o = \frac{M_o \cdot n}{9550}$$

F = force (N)
 P = pulley action perimeter (mm)
 S = safety factor 1,2 ... 2
 M_{leer} = no-load torque (Nm)
 n = rpm pulley (min⁻¹)
 M_o = driving torque (Nm)
 P_o = motor power (KW)

$$f = \frac{F \cdot L^3}{E \cdot I \cdot 192}$$

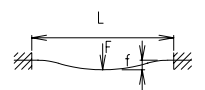

f = deflection (mm)
 F = load (N)
 L = free length (mm)
 E = elastic modulus 70000 (N/mm²)
 I = second moment of area (mm⁴)

Positioning system MLZ 60, 60S, 80, 80S, 100

Dimensions (mm)

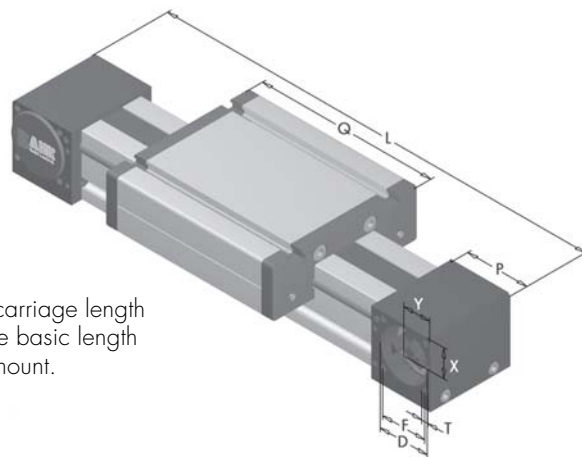
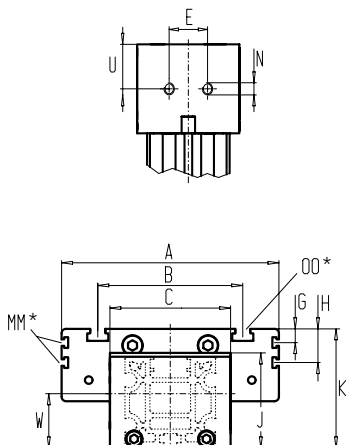

Increasing the carriage length will increase the basic length by the same amount.

3.1



*For slide-nuts refer to main catalogue chapter 2.2 page 2

Size □	Basic length L	A	B	C	D	E	F	G	H	J	K	MM for	N	OO for	P	Q	T	U	W	X	Y	Basic weight	Weight per 100 mm
MLZ 60	290	144	96	80	47	30	42	-	-	63	79	-	M 8	M 8	59	168	M 6	29,5	36	27	26	4,7 kg	0,6 kg
MLZ 60S	315	170	108	80	47	30	42	-	-	63	83	-	M 8	M 8	59	194	M 6	29,5	30	27	26	5,8 kg	0,62 kg
MLZ 80	375	170	117	100	68	40	60	10	30	93	110	M 6	M 10	M 10	90	194	M 8	47,5	40	45	40	9,6 kg	1,0 kg
MLZ 80 S	395	190	126	100	68	40	60	12,5	30	93	111	M 6	M 10	M 8	90	214	M 8	47,5	40	45	40	10,8 kg	1,0 kg
MLZ 100	530	230	155	130	90	110	80	-	29	120	139	M 10	M 12	M 10	110	300	M 10	55	50	49	50	22,5 kg	1,55 kg

0 Choice of guide body profile:
(0) Standard **(1)** stainless guide rods **(2)** stainless guide rods and screws **(3)** stainless guide rods, rollers and screws

Choice of carriages:



For standard carriage length see 'Q' in table. Non-standard length on request. The longer the carriage, the higher the load capacity.



Top and bottom carriages are rigidly joined, enabling higher loads to be applied. This increases the basic length by 16 - 20 mm. Thickness of jointing plate refer to main catalogue chapter 1.2 page 6.

0 Coupling - shaft mounting:

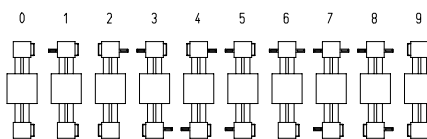
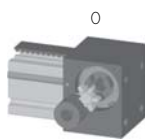

Version 9 is the same as 0, but with double sided coupling claw.

The standard version is supplied without shaft.

Belt table

Code No.	Size	Belt	mm/rev.	Number of teeth
0 4	60 (S)	5M25	130	26
0 7	80 (S)	8M30	176	22
0 9	100	8M50	224	28

Shaft dimensions

Size	Shaft ø h6 x length	Key
60 (S)	14 x 35	5x5x28
80 (S)	18 x 45	6x6x40
100	22 x 45	6x6x40

Basic length + stroke = total length

MLZ 60 1 0 0 0 0 4 1 01500

Pos. 1 2 3 4 5 6 7

Sample ordering code:

MLZ 60 with standard body profile, standard carriage, coupling claw on one side, 1210 mm stroke.

