

# Positioning system ELFZ 60S, 80S, 100, 125

## Specifications

3.1

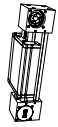
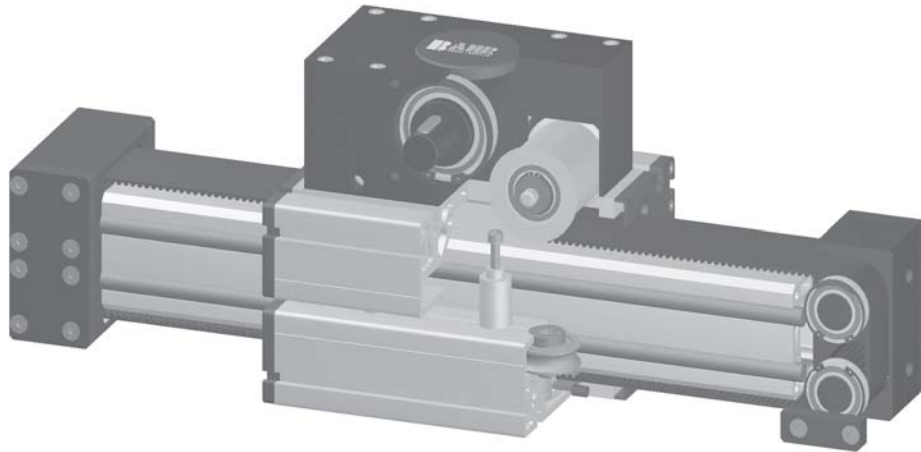

### Function:

This special lifting unit consists of an aluminium square profile with hardened steel guide rods. The carriages, which has internal linear ball bearings that can be adjusted free of play is driven along the guide rods by a timing belt. The rotating timing belt pulleys have maintenance-free ball bearings. One rotation of the drive pulley complies with linear 1/2 circumference of the drive pulley. Belt tension can be readjusted by a simple tensioning device in one of the carriages. This device can also be used for symmetrical adjustment of two or more linear units running parallel.

### Fitting position:

As required. Max. length without joints 6.000 mm.

### Carriage mounting:

By T-slots.

### Unit mounting:

By T-slots or tapped holes in the bearing blocks, or mounting sets.

### Belt type:

HTD with steel reinforcement, no backlash when changing direction, repeatability  $\pm 0,1$  mm.

Forces and torques	Size	ELFZ 60S		ELFZ 80S		ELFZ 100		ELFZ 125	
	Forces/Torques	static	dynamic	static	dynamic	static	dynamic	static	dynamic
$F_x$ (N)		3600	3200	6200	5400	8700	7600	12000	10400
$F_y$ (N)		8200	6200	9200	7200	16000	13000	24000	18000
$F_z$ (N)		4320	3200	6000	3600	7200	4400	12000	9000
$M_x$ (Nm)		176	130	340	280	600	460	1200	900
$M_y$ (Nm)		380	280	540	460	800	540	1500	1200
$M_z$ (Nm)		460	340	600	440	1500	1000	2700	2300
<b>All forces and torques relate to the following:</b> existing values $\frac{F_y}{F_{y_{dyn}}} + \frac{F_z}{F_{z_{dyn}}} + \frac{M_x}{M_{x_{dyn}}} + \frac{M_y}{M_{y_{dyn}}} + \frac{M_z}{M_{z_{dyn}}} \leq 1$ values of table									
<b>No-load torque</b>									
Nm		1,3		1,5		2		2	
<b>Speed</b>									
(m/sec) max		4		4		4		4	
<b>Drive torque</b>									
max (Nm)		48		120		386		500	
<b>Geometrical moments of inertia of aluminium profile</b>									
$I_x$ mm <sup>4</sup>		6,79x10 <sup>5</sup>		1,89x10 <sup>6</sup>		4,44x10 <sup>6</sup>		10,15x10 <sup>6</sup>	
$I_y$ mm <sup>4</sup>		6,97x10 <sup>5</sup>		1,89x10 <sup>6</sup>		4,48x10 <sup>6</sup>		10,15x10 <sup>6</sup>	
E-Modulus N/mm <sup>2</sup>		70000		70000		70000		70000	

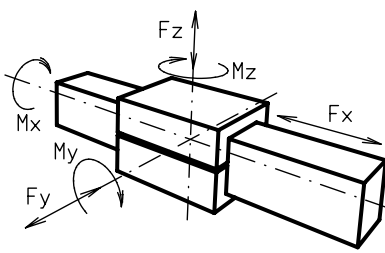

For life-time calculation of rollers use our CD-ROM or homepage!

### Formula: ELFZ

Driving torque:

$$M_o = \frac{F \cdot P \cdot S}{2000 \cdot \pi \cdot 2} + M_{leer}$$

$$P_o = \frac{M_o \cdot n}{9550}$$

- F = force (N)
- P = pulley action perimeter (mm)
- S = safety factor 1,2 ... 2
- $M_{leer}$  = no-load torque (Nm)
- n = rpm pulley (min<sup>-1</sup>)
- $M_o$  = driving torque (Nm)
- $P_o$  = motor power (KW)

$$f = \frac{F \cdot L^3}{E \cdot I \cdot 192}$$

- f = deflection (mm)
- F = load (N)
- L = free length (mm)
- E = elastic modulus 70000 (N/mm<sup>2</sup>)
- I = second moment of area (mm<sup>4</sup>)

# Positioning system ELFZ 60S, 80S, 100, 125

Dimensions (mm)

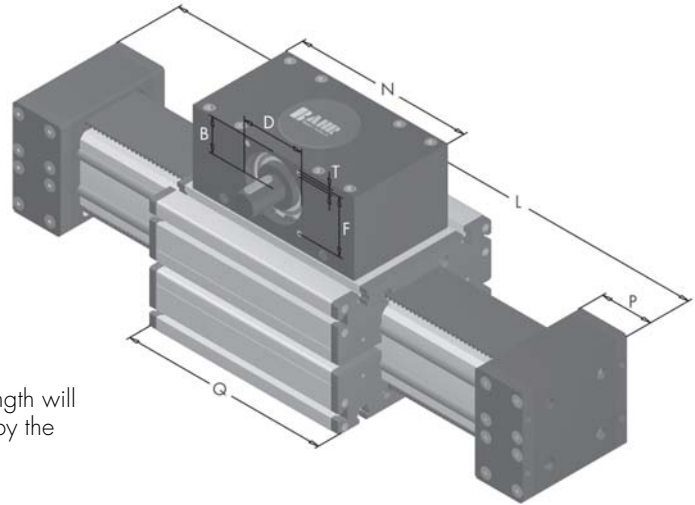
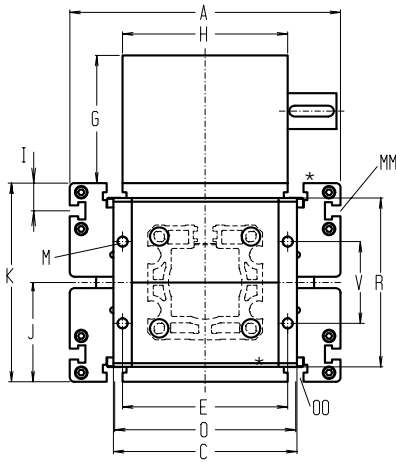

Increasing the carriage length will increase the basic length by the same amount.

\*For slide-nuts refer to chapter 2.2 page 2

Size	Basic length L	A	B	C	D	E	F	G	H	I	J	K	MM for	M	N	OO for	P	Q	R	S	T	V	Basic weight	Weight per 100 mm	
ELFZ 60S		170	34	108	68			105	100	-	53	106	-	M8	180	M8		230	M8						
ELFZ 80S	600	190	60	126	90	134	80	139	130	12,5	71	142	M6	M10	270	M8	130	328	8x7x40	30x45	M10	70	51 kg	1,20 kg	
ELFZ 100	530	230	62	170	110	150	100	143	160	30	90	180	M10	M10	310	M10	77	365	12x8x50	40x55	M10	80	69 kg	1,80 kg	
ELFZ 125	560	295	62	200	110	180	100	139	180	30	107,5	215	M10	M12	310	M12	92	365	12x8x50	40x55	M10	89	87,5 kg	2,70 kg	

## Choice of guide body profile:

- 0** (0) Standard (1) stainless guide rods (2) stainless guide rods and screws (3) stainless guide rods, rollers and screws

## Choice of carriages:

(0)



(1)



## Selection of shaft mounting:

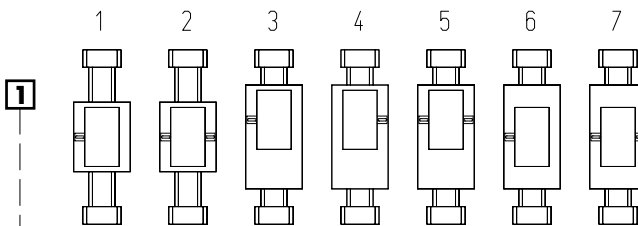

## Belt table

Code No.	Size	Belt	mm/eqv.	linear	Number of teeth
<b>0 3</b>	60S	8M30	192	96	24
<b>0 4</b>	80S	8M50	256	128	32
<b>0 4</b>	100	8M70	304	152	38
<b>0 9</b>	125	8M100	304	152	38

## Shaft dimensions

Size	Shaft ø h6 x length	Key
60(S)	18 x 45	6x6x40
80	30 x 45	8x7x40
100	40 x 55	12x8x50
125	40 x 55	12x8x50

Basic length + stroke = total length

ELFZ 125 0 0 0 1 0 4 1 01500

Pos. 1 2 3 4 5 6 7

For combination kits and connecting elements refer to chapter 2.2

Sample ordering code:

ELFZ 125 with standard body profile, standard carriage, shaft Pos. 1, 940 mm stroke