

	Parameter	Remarks	Symbol	Unit	UXX3		UXX6		UXX9		UXX12		UXX18
					N	S	N	S	N	S	N	S	N
Performance	Winding type				N	S	N	S	N	S	N	S	N
	Motor type, max voltage ph-ph				3-phase synchronous Ironless, 300V _{dc}								
	Peak Force @ 20°C/s	magnet @ 25°C	F _p	N	700		1400		2100		2800		4200
	Continuous Force*	coils @ 110°C	F _c	N	141		282		423		564		846
	Maximum Speed**	@ 300 V	v _{max}	m/s	2.7	6.6	2.7	6.6	2.7	6.6	2.7	6.6	2.7
	Motor Force Constant	coils @ 25°C	K	N/A _{rms}	124	50.3	124	50.3	124	50.3	124	50.3	124
Electrical	Motor Constant	coils @ 25°C	S	N ² /W	323		647		970		1293		1940
	Peak Current	magnet @ 25°C	I _p	A _{rms}	5.6	13.9	11.3	28	16.9	42	22.6	56	34
	Maximum Continuous Current	coils @ 110°C	I _c	A _{rms}	1.14	2.80	2.27	5.6	3.4	8.4	4.5	11.2	6.8
	Back EMF Phase-Phase Peak		B _{emf}	V _{dc} / m/s	101	41	101	41	101	41	101	41	101
	Resistance per Phase	coils @ 25°C ex. cable	R _f	Ω	15.8	2.6	7.9	1.29	5.3	0.86	4.0	0.65	2.6
	Induction per Phase	l < 0.6 Ip	L _f	mH	28	4.6	14	2.3	9	1.5	7	1.2	4.7
Thermal	Electrical Time Constant	coils @ 25°C	τ _e	ms	1.8		1.8		1.8		1.8		1.8
	Maximum Continuous Power Loss	all coils	P _c	W	82		165		247		330		494
	Thermal Resistance		R _{th}	°C/W	1.04		0.52		0.35		0.26		0.17
	Thermal Time Constant	minimum	τ _{th}	s	156		156		156		156		156
Mechanical	Temperature Sensors				PTC 1kΩ and NTC								
	Coil Unit Weight	ex. cables	M	kg	0.55		0.95		1.35		1.75		2.55
	Coil Unit Length	ex. cables	L	mm	134		248		362		476		704
	Motor Attraction Force		F _a	N	0		0		0		0		0
	Magnet Pitch NN		τ	mm	57		57		57		57		57
	Cable Weight		m	gr/m	180		180		180		180		180
	Cable Type (Power)	length 1 m	d	mm (AWG)	6.4 (18) except UXX3S***								
	Cable Type (Sensor)	length 1 m	d	mm (AWG)	4.3 (26)								

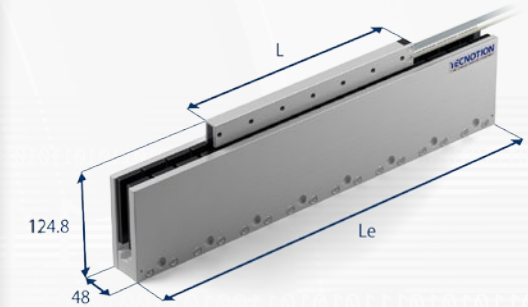

UXX6 in 456mm magnet yoke shown

UXX3S Power Cable (FLEX)	
Cable Type	9.0 (21) mm (AWG)
Cable Life	5,000,000 cycles
Bending Radius Static	4x cable diameter
Bending Radius Dynamic	10x cable diameter

Magnet yoke dimensions			
Le (mm)	114	171	456
M6 bolts	2	3	8
Mass (kg/m)	24		
Magnet yokes can be butted together.			

All specifications ±10%

*Max. continuous force depends on the thermal resistance, cooling surface and ambient temperature of your application. Download our simulation tool to check the motor's thermal behavior in the application.

** Actual values depend on bus voltage. Please check the F/V diagram in our simulation tool.

*** The UXX3S is only available with a FLEX power cable. The specifications for this cable can be found in the box on the right side of this page.

