

Parameter	Remarks	Symbol	Unit	TB12		TB15		TB30	
Winding type				N	S	N	S	N	S
Motor type, max voltage ph-ph				3-phase synchronous Iron core, 600V _{dc}					
Ultimate Force @ 10°C/s	magnet @ 25°C	F _u	N	1800		2250		4500	
Peak Force @ 6°C/s	magnet @ 25°C	F _p	N	1600		2000		4000	
Continuous Force*	coils @ 100°C	F _c	N	760		950		1900	
Maximum Speed**	@ 560 V	V _{max}	m/s	3	6	2.5	6	2.5	6
Motor Force Constant	I < 0.6 Ip	K	N/A _{rms}	186	93	225	93	225	93
Motor Constant	coils @ 25°C	S	N ² /W	1750		2150		4300	
Ultimate Current	magnet @ 25°C	I _u	A _{rms}	13.0	26	13.5	33	27	66
Peak Current	magnet @ 25°C	I _p	A _{rms}	10.0	20	10.0	25	20	50
Maximum Continuous Current	coils @ 100°C	I _c	A _{rms}	4.1	8.2	4.2	10.2	8.5	20.5
Back EMF Phase-Phase Peak		B _{emf}	V _{dc} / m/s	152	76	183	76	183	76
Resistance per Phase	coils @ 25°C ex. cable	R _f	Ω	6.3	1.6	7.6	1.3	3.8	0.65
Induction per Phase	I < 0.6 Ip	L _f	mH	51	13	60	10	30	5
Electrical Time Constant	coils @ 25°C	τ _e	ms	8		8		8	
Maximum Continuous Power Loss	all coils	P _c	W	430		530		1060	
Thermal Resistance		R _{th}	°C/W	0.15		0.12		0.06	
Thermal Time Constant	minimum	τ _{th}	s	90		90		90	
Temperature Sensors				PTC 1kΩ and KTY21-6					
Coil Unit Weight	ex. cables	M	kg	4.9		5.9		11.6	
Coil Unit Length	ex. cables	L	mm	244		290		568	
Motor Attraction Force	rms	F _a	N	3400		4150		8300	
Magnet Pitch NN		τ	mm	24		24		24	
Cable Weight		m	gr/m	300		300		300	
Cable Type (Power)	length 1 m	d	mm (AWG)	11.9 (14)					
Cable Type (Sensor)	length 1 m	d	mm (AWG)	4.3 (26)					

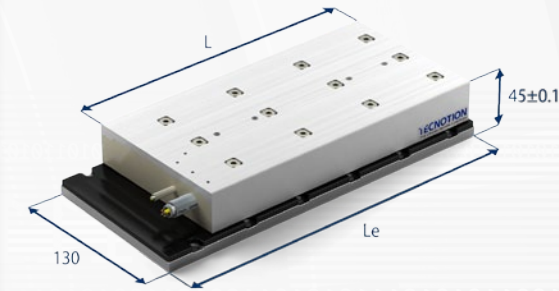

TB12 on 288mm magnet plate shown

Magnet plate dimensions		
Le (mm)	192	288
M5 bolts	8	12
Mass (kg/m)	10.5	
Magnet plates can be butted together.		

All specifications ±10%

*Max. continuous force depends on the thermal resistance, cooling surface and ambient temperature of your application. Download our simulation tool to check the motor's thermal behavior in the application.

** Actual values depend on bus voltage. Please check the F/V diagram in our simulation tool.

Mounting instructions and flatness or parallelism requirements can be found in the Iron Core installation manual. CAD files and 3D models can be downloaded from our website.

MAGNET PLATES

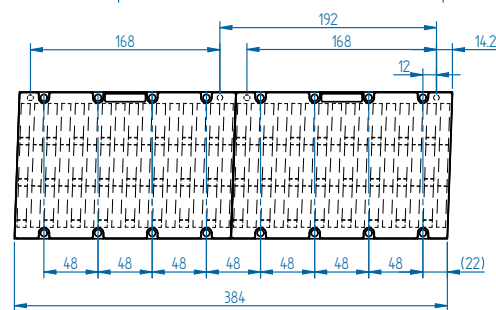
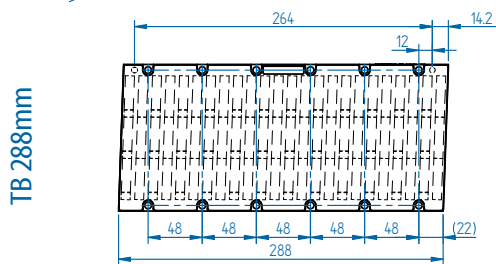
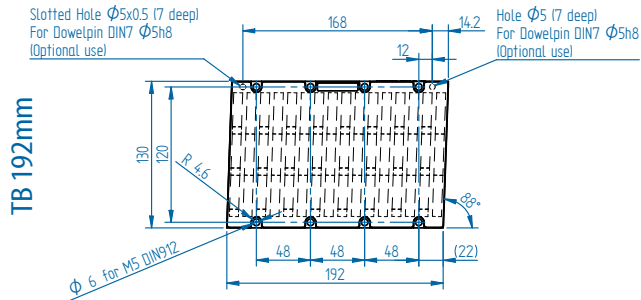

COIL UNITS

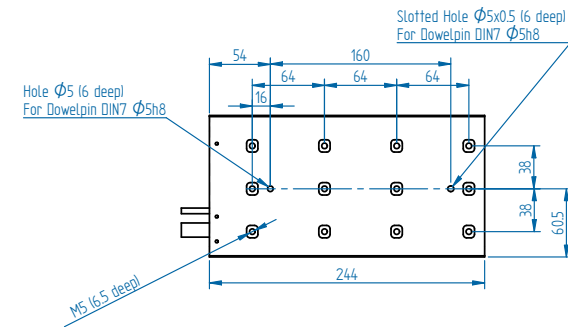
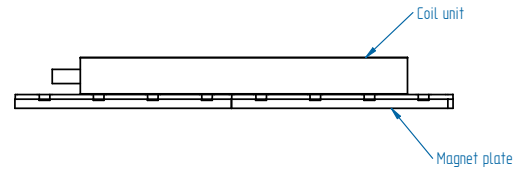
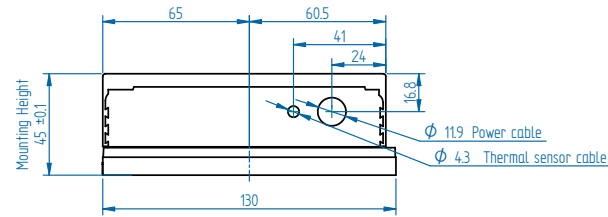

TB15

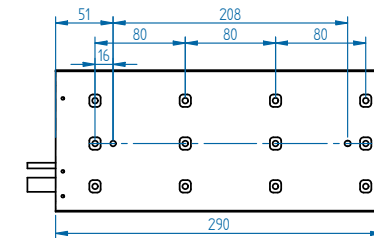

TB30

